

Reflection Interference

How To Avoid Reflection Interference

The Problem

To determine how close fiberoptic sensor tips can be mounted to sidewalls or to each other without interference.

The Solution

Unlike laser sensors which collimate light to a point, Philtec's fiberoptic probes spread light out like a flashlight. The angle the light beam spreads depends upon the specific model and it is provided on our Product Data Sheets for each model. Interference calculations can be made based upon the light beam spread and the operating gaps for any model sensor.

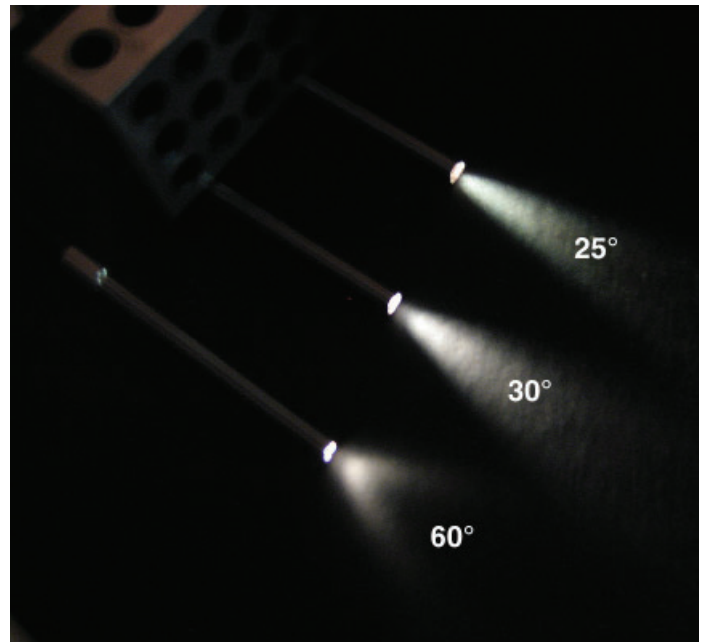
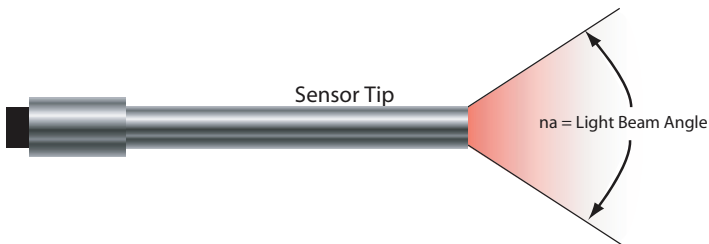

Numerical Aperture

Numerical aperture (na) refers to the maximum angle at which light can enter, propagate through and exit an optical fiber. Philtec uses 3 different types of fibers to construct sensors. These fibers have the following properties:

FIBER na	BEAM ANGLE	Models
0.55	66°	D20, D63, RC19, RC25, RC31, RC59
0.25	30°	D21, D47, D100, D125, D169, RC20, RC32, RC60, RC100
0.22	25°	D170, D171, D240, RC171, RC225, RC290

Reflection Interference

TARGET SPOT SIZE

The target spot size is equal to the size of the fiber bundle. Any light rays that diverge away from the projected area of the fiber bundle are reflected away from the sensor tip - *unless the sensor is too close to some other object.*

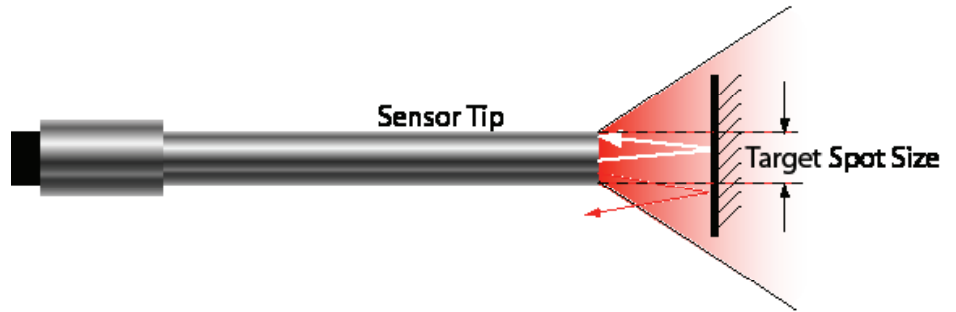

INTERFERENCE LIMITS

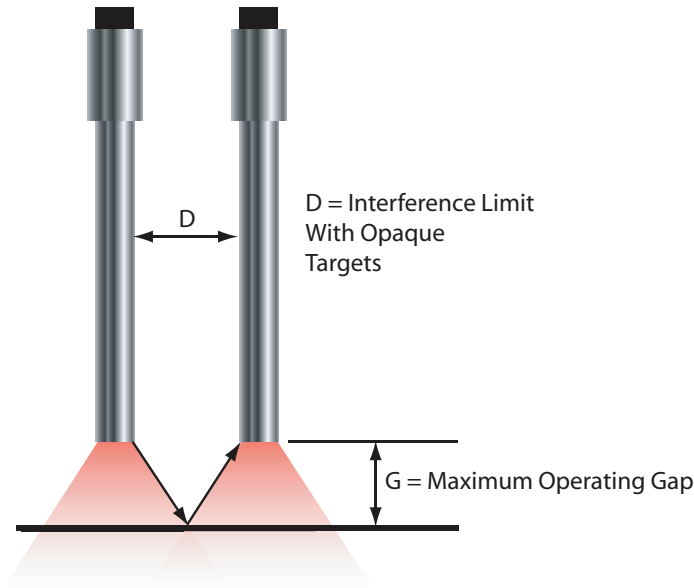

OPAQUE TARGETS

$$D = 2 * G * \tan(n_{air} / 2)$$

na, degrees	D
25	0.44 * G
30	0.54 * G
66	1.3 * G

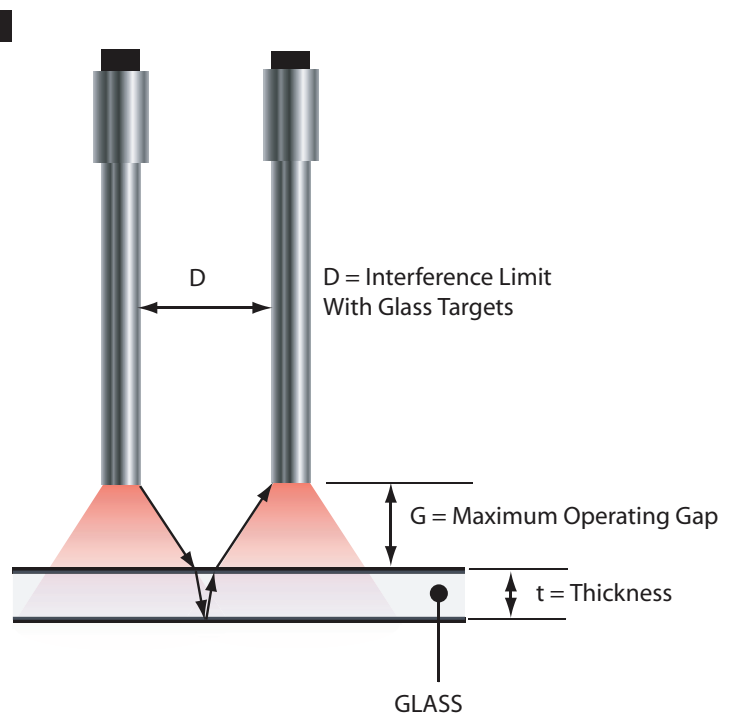

GLASS TARGETS

$$D = 2 * G * \tan(n_{air} / 2) + 2 * t * \tan(n_{glass} / 2)$$

na _{air}	na _{glass}	D
25	16	0.44 * G + 0.29t
30	20	0.54 * G + 0.35t
66	43	1.3 * G + 0.8t

EXAMPLE

For a model RC171 sensor and opaque target, $n_a = 25^\circ$ and $G = 12.7$ mm. Therefore, $D = 0.44 * 12.7$; $D = 5.6$ mm
 For a model RC171 sensor and 4 mm glass target, $D = 0.44 * 12.7 + 0.29 * 4$; $D = 6.8$ mm