

Fiberoptic Displacement Sensor

Model DMS-RC25

Fiberoptic Cable & Sensor Tip - Actual Size

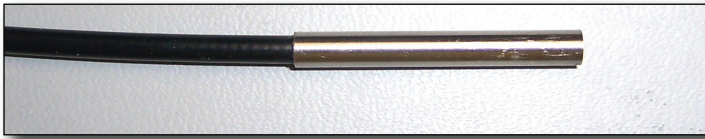

For The Measurement of Distance, Displacement and Vibration
With The Best Resolution in the RC Series

Features

- Reflectance Compensated Output*
- 0.64 x 3.18 mm Spot Size
- 0.76 mm Operating Range

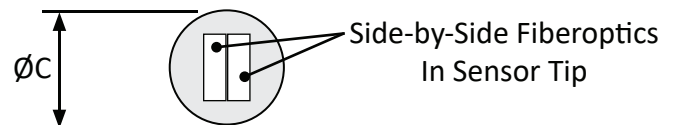

Tip & Cable Dimensions

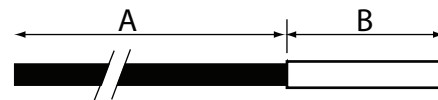

OPERATING PRINCIPLE. These are reflective type transducers based upon detecting the intensity of reflected light. RC Model sensors have a pair of fiberoptic detectors in the sensor tip. Light reflected off a target follows two separate paths back to the electronics where a ratiometric calculation provides the distance measurement which is independent of varying surface reflectance; i.e., **reflectance compensated**.

FEATURE	mm	inch
Tip Outer Diameter, $\varnothing B$	4.75	0.187
Fiberoptic Area	0.64 x 3.175	0.025 x .125
Tip Length, B	38.1	1.5
Cable Length, A	914	36
Cable Diameter, $\varnothing A$	3.4	0.133
Cable Min. Bend Radius	19	0.75

*These sensors provide a **linearized distance output** with RS232 or USB communication. Dynamic light signals reflected from target surfaces are converted to distances by comparing the sensor signals to gap calibration tables stored on-board the sensor.

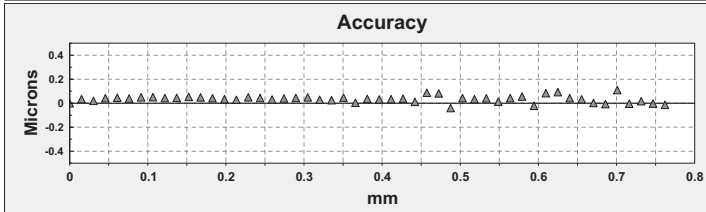
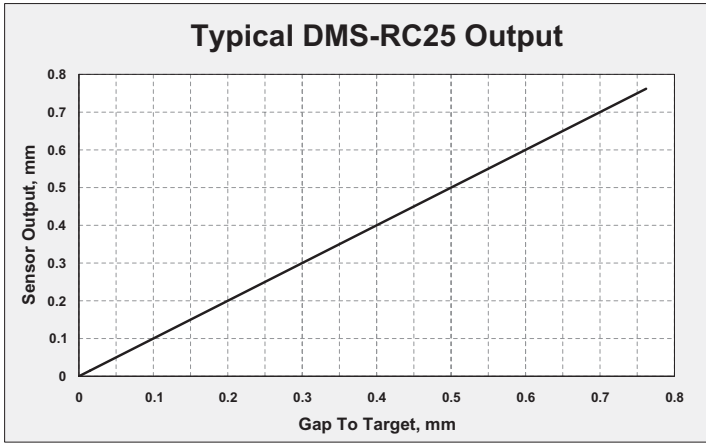

Sensor Accuracy is measured at 2.5 samples/sec.

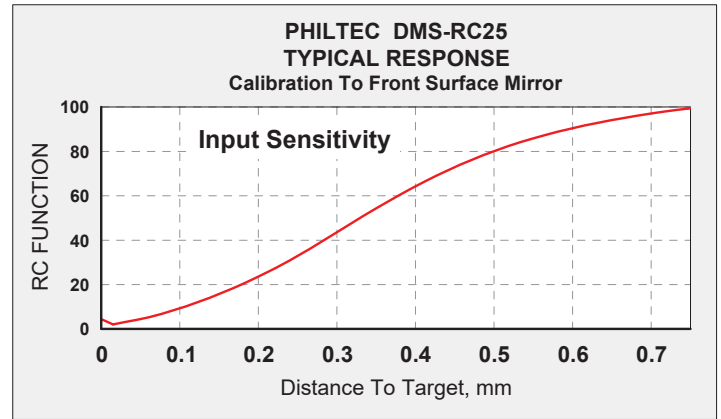

The analog signal input to the sensor’s microprocessor (shown above) is converted to a linearized distance output by comparing the input signals to gap calibration tables stored on-board the sensor. The sensor can be gapped for measurements anywhere within the sensor’s total operating range. Optimum performance is achieved where the RC input signal has the steepest slope (highest sensitivity, ~0.1 - 0.6 mm).

Standard Specifications - DMS-RC25					
Electronics		Fiberoptics		USB or RS232	
Light Source	850 nm	Light Beam Spread	66°	Total Range	0.76 mm
Input Voltage	+12 VDC	Cable Sheathing	PVC over Steel Monocoil	Linear Range	0 - 0.76 mm
Input Current	500 ma max	Tip Epoxy Outgas	0.3% @ 200°C 2.4% @ 300°C	Reflectance Resolution	0.5%
Bandwidth	5 KHz max	Tip Operating Pressure	10 bar	Temperature Resolution	0.06°C
Iso-thermal Drift	0.05%	Tip Operating Temperature	-55 to 200°C continuous; to 300°C intermittent 1-2 hours	Resolution*	** <u>samples/sec</u> <u>pk-pk</u>
Weight	1.1 kg, 2.4 lbs.	Fibers	Glass	ADC AVG = 2	5208 50 nm
				ADC AVG = 16	651 30 nm
				ADC AVG = 256	41 10 nm
				ADC AVG = 4096	2.5 3 nm

NOTES:

*These specifications represent best case performance where:

- the target is flat, smooth and highly reflective
- the sensor is perpendicular to the target
- the sensor is gapped to its range of highest sensitivity (~mid-range)
- fiberoptic cable lengths are standard and the cables are not connectorized

**DMS Control Software includes a data averaging filter for averaging data samples from: 2 samples (the fastest rate) to 4096 samples (best resolution).

Internally, the sensor continuously reads target data at a clock rate of 10416.75 Hz. ADC AVG = the number of internal readings averaged before sending data out to the PC.

Samples/Sec for any ADC AVG setting can be calculated as follows:

- S/S = 10,416.75 / ADC AVG

Three Instruments To Choose From:

- **Model mDMS-RC25** ... miniDMS with RS232 output
- **Model muDMS-RC25** ... miniDMS with USB output
- **Model mu2DMS-RC25** ... Two Channel DMS with USB & RS232 outputs



mDMS-RC25

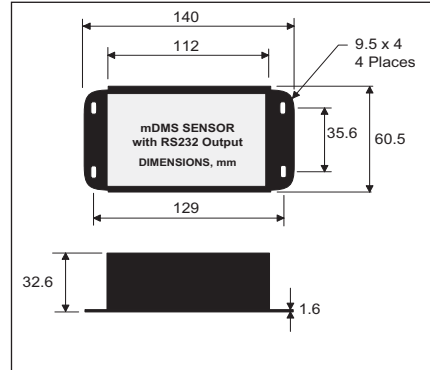

1. mDMS units include:

- Electronics with RS-232 communication



muDMS-RC25

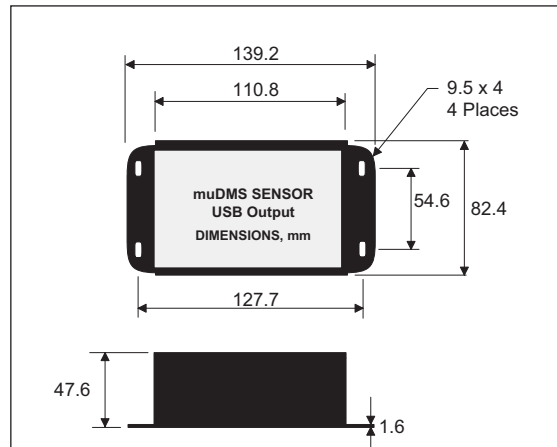

2. muDMS units include:

- Electronics with USB communication



mu2DMS-RC25

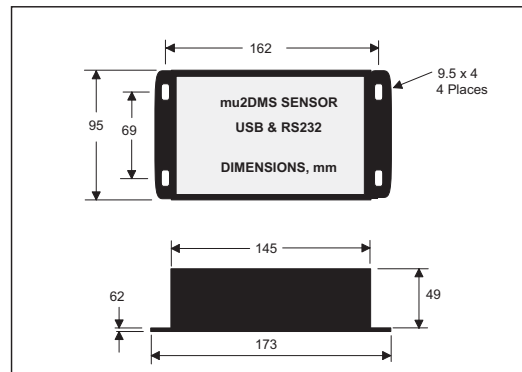

3. mu2DMS units include:

- Electronics with USB and RS232 communication